

Cliente _____ Rif. ordine / Offerta _____ Data ___/___/___ Rif. _____ Ubicazione _____

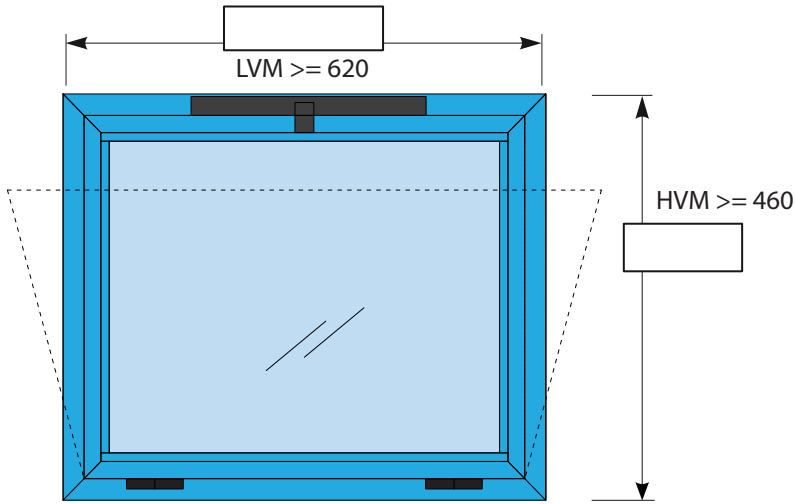

FERMAVETRI DAL
"LATO A TIRARE

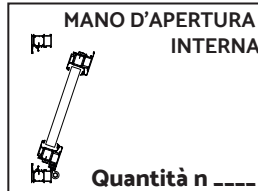

DETTAGLIO ATTUATORE (corsa = 300 mm)

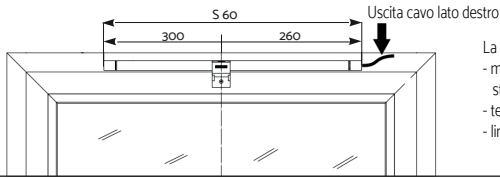

La gestione del serramento avviene con:
- motorizzazione tipo SLIMCHAIN SINCRO 1,
- staffaggio tipo A
- tensione di esercizio 24V
- limitatore di apertura

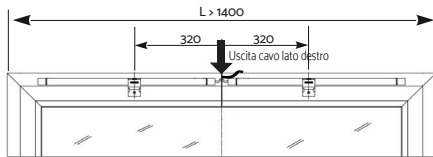

La gestione del serramento avviene mediante:
- motorizzazione tipo SLIMCHAIN SINCRO 2,
- staffaggio tipo A
- tensione di esercizio 24V
- limitatore di apertura

ANTA-TELAIO

TELAIO "L" su muro - ANTA "Z"



TELAIO "Z" su muro - ANTA "Z"

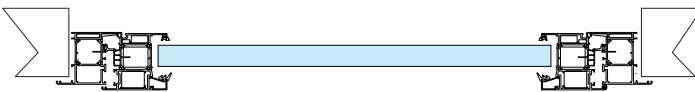

NOTE:

TIPOLOGIE DI TELAIO

TELAIO "L"

TELAIO "Z"

"Z" 3 LATI
"L" INFERIORE

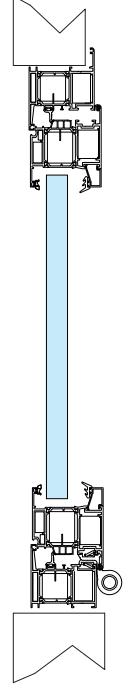
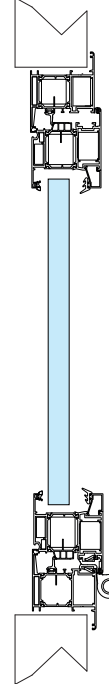
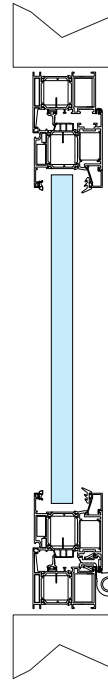

TIPOLOGIE DI FISSAGGIO

FORI DI ANCORAGGIO PER SOTTOSTRUTTURA

FORI DI ANCORAGGIO PER TASSELLI

FINITURE

DI SERIE - RAL 9010 LISCIO OPACO

ALTRA FINITURA RAL _____

BICOLORE RAL _____

ACCESSORI

COPRIFILI ANGOLARI 40X20 mm

VETRI INCAMERATI

VETRI CON PELLICOLA UV

ATTUATORE FINITURA ARGENTO

Timbro e firma per accettazione

Cliente _____ Rif. ordine / Offerta _____ Data ___ / ___ / ___ Rif. _____ Ubicazione _____

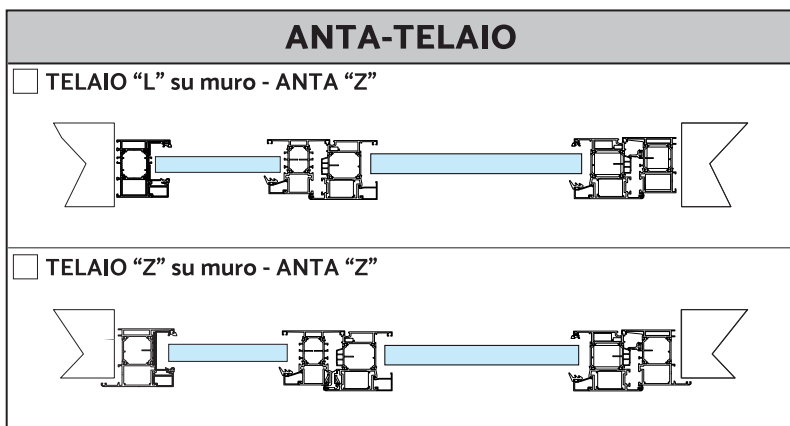
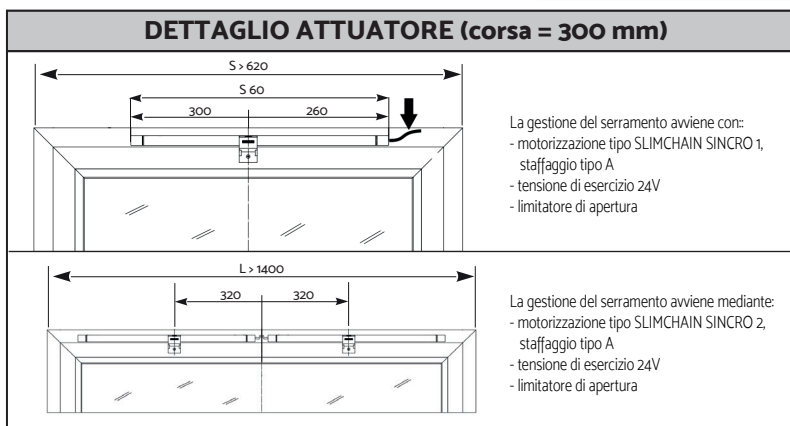
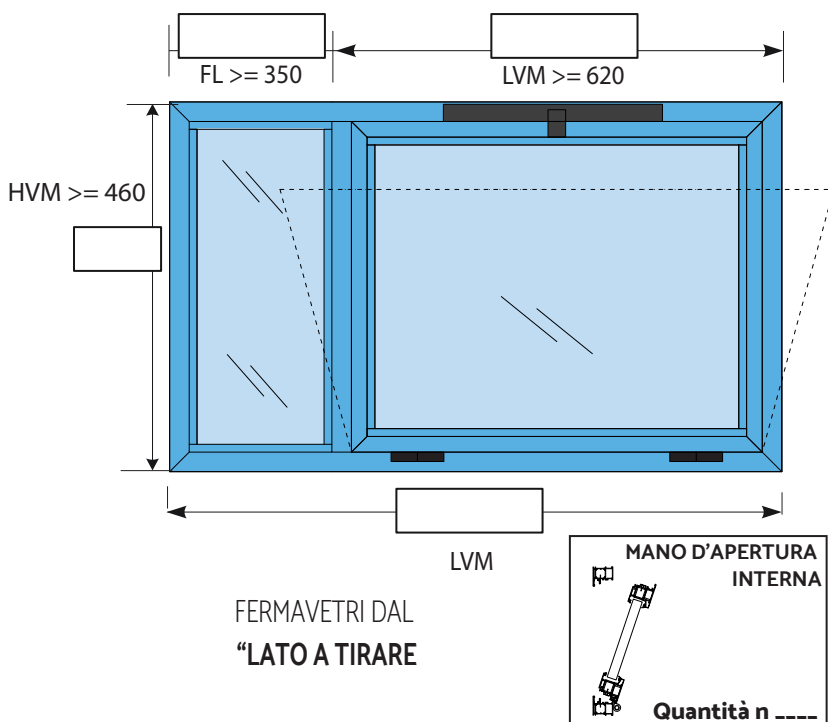

NOTE:

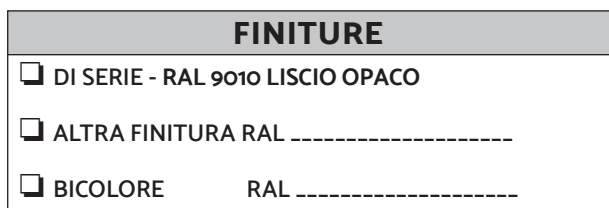
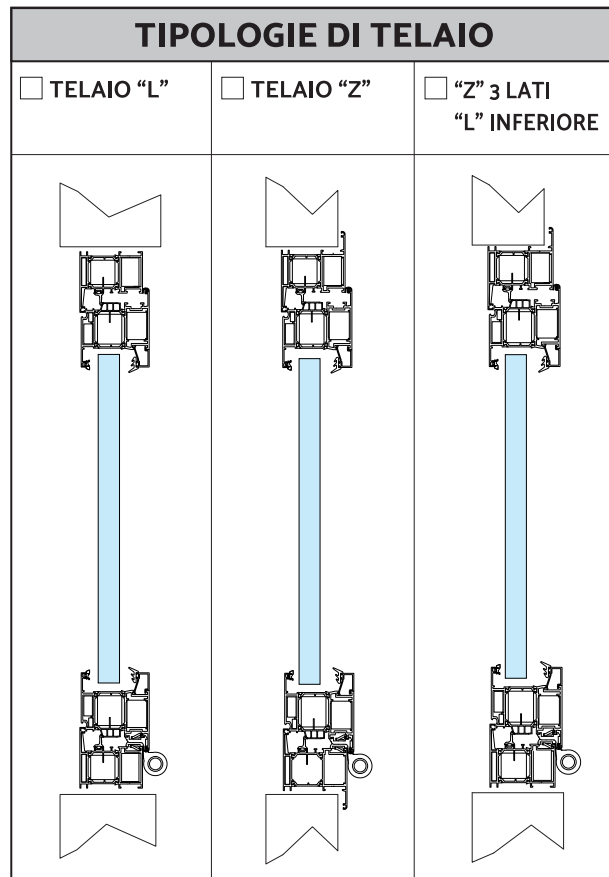

Timbro e firma per accettazione

Cliente _____ Rif. ordine / Offerta _____ Data ____ / ____ / ____ Rif. _____ Ubicazione _____

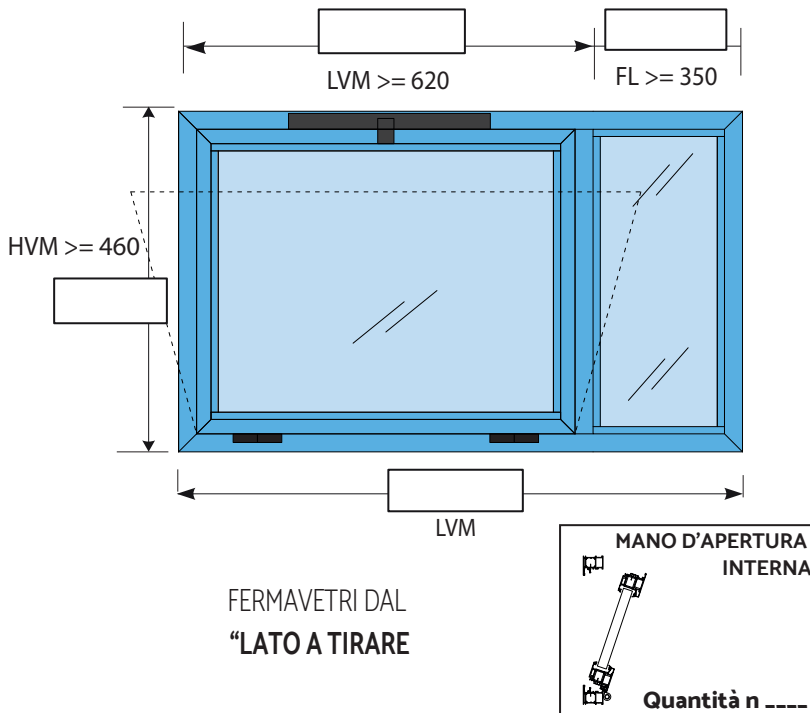

DETTAGLIO ATTUATORE (corsa = 300 mm)

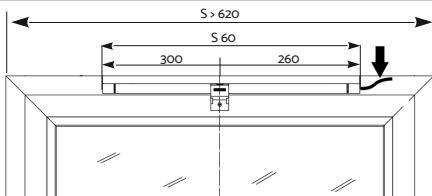

La gestione del serramento avviene con:
- motorizzazione tipo SLIMCHAIN SINCRO 1,
staffaggio tipo A
- tensione di esercizio 24V
- limitatore di apertura

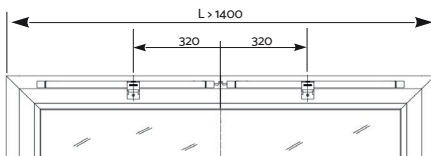

La gestione del serramento avviene mediante:
- motorizzazione tipo SLIMCHAIN SINCRO 2,
staffaggio tipo A
- tensione di esercizio 24V
- limitatore di apertura

ANTA-TELAIO

TELAIO "L" su muro - ANTA "Z"

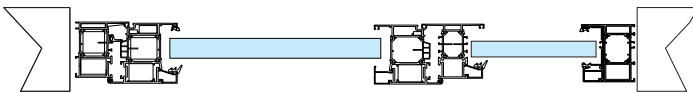

TELAIO "Z" su muro - ANTA "Z"

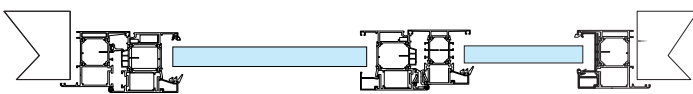

TIPOLOGIE DI TELAIO

TELAIO "L"

TELAIO "Z"

"Z" 3 LATI
"L" INFERIORE

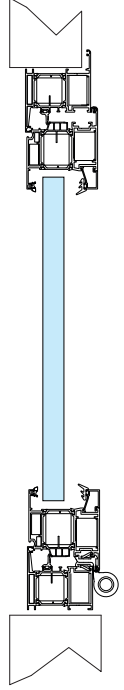
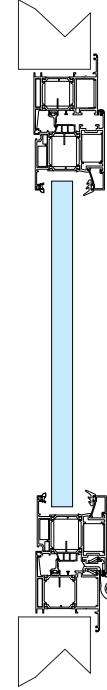
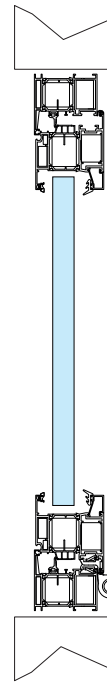

TIPOLOGIE DI FISSAGGIO

FORI DI ANCORAGGIO PER SOTTOSTRUTTURA

FORI DI ANCORAGGIO PER TASSELLI

FINITURE

DI SERIE - RAL 9010 LISCIO OPACO

ALTRA FINITURA RAL _____

BICOLORE RAL _____

ACCESSORI

COPRIFILI ANGOLARI 40X20 mm

VETRI INCAMERATI

VETRI CON PELLICOLA UV

ATTUATORE FINITURA ARGENTO

Timbro e firma per accettazione

Tel.: +39 0832 757979
E-mail: info@glassfire.it

EI 30
Sp. = 75 mm

EI 60
Sp. = 75 mm

EI 90
Sp. = 75 mm

Cliente _____ Rif. ordine / Offerta _____ Data ____ / ____ / ____ Rif. _____ Ubicazione _____

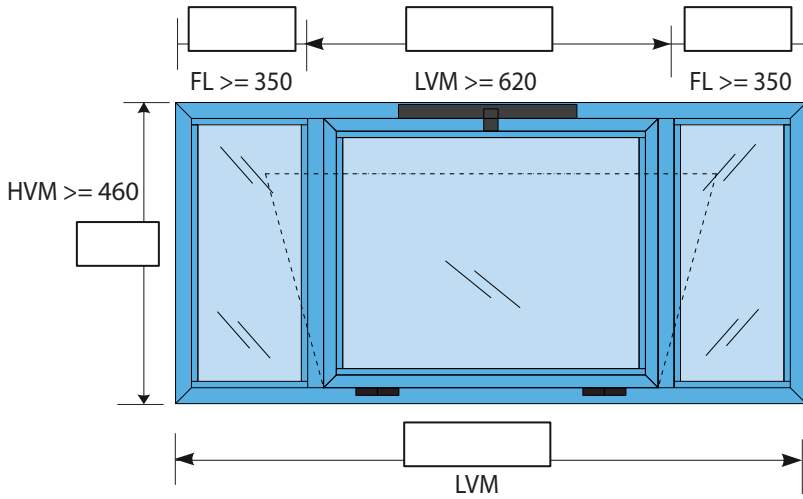

FERMAVETRI DAL
"LATO A TIRARE"

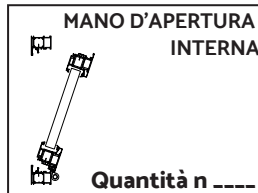

DETTAGLIO ATTUATORE (corsa = 300 mm)

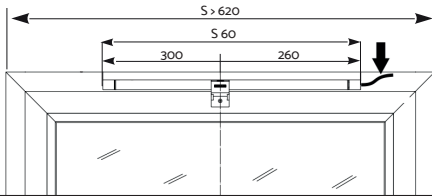

La gestione del serramento avviene con:
- motorizzazione tipo SLIMCHAIN SINCRO 1,
staffaggio tipo A
- tensione di esercizio 24V
- limitatore di apertura

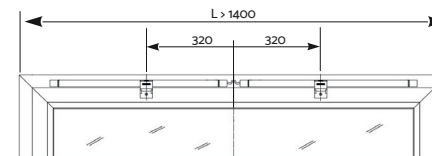

La gestione del serramento avviene mediante:
- motorizzazione tipo SLIMCHAIN SINCRO 2,
staffaggio tipo A
- tensione di esercizio 24V
- limitatore di apertura

ANTA-TELAIO

TELAIO "L" su muro - ANTA "Z"

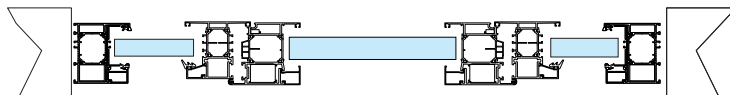

TELAIO "Z" su muro - ANTA "Z"



NOTE:

TIPOLOGIE DI TELAIO

TELAIO "L"

TELAIO "Z"

"Z" 3 LATI
"L" INFERIORE

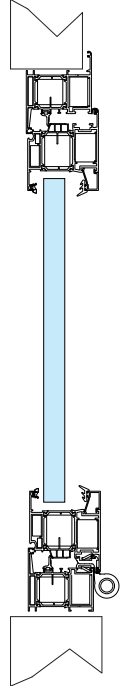
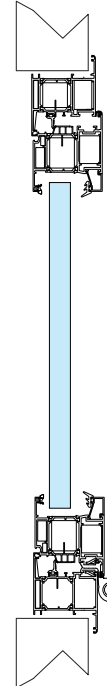
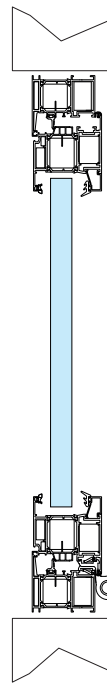

TIPOLOGIE DI FISSAGGIO

FORI DI ANCORAGGIO PER SOTTOSTRUTTURA

FORI DI ANCORAGGIO PER TASSELLI

FINITURE

DI SERIE - RAL 9010 LISCIO OPACO

ALTRA FINITURA RAL _____

BICOLORE RAL _____

ACCESSORI

COPRIFILI ANGOLARI 40X20 mm

VETRI INCAMERATI

VETRI CON PELLICOLA UV

ATTUATORE FINITURA ARGENTO

Timbro e firma per accettazione

Cliente _____ Rif. ordine / Offerta _____ Data ____/____/____ Rif. _____ Ubicazione _____

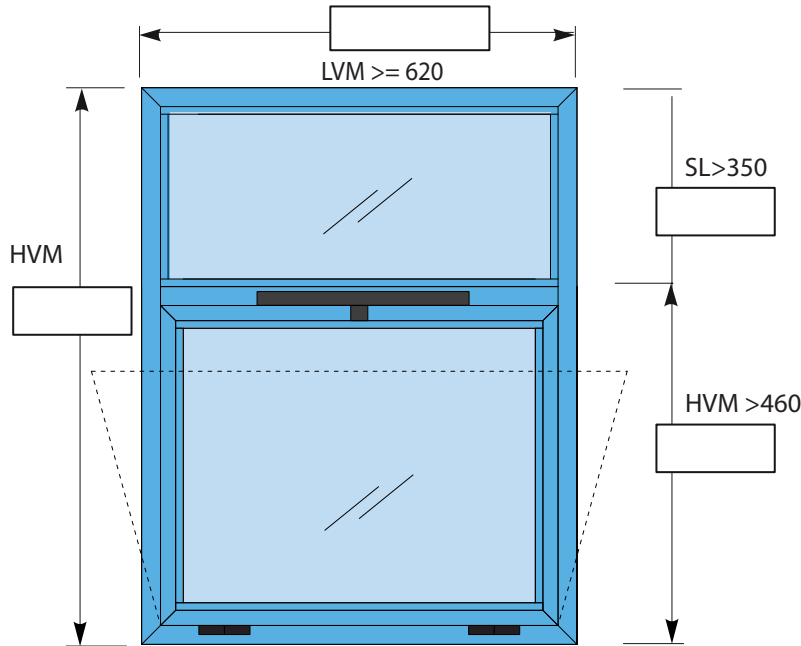

FERMAVETRI DAL
"LATO A TIRARE"

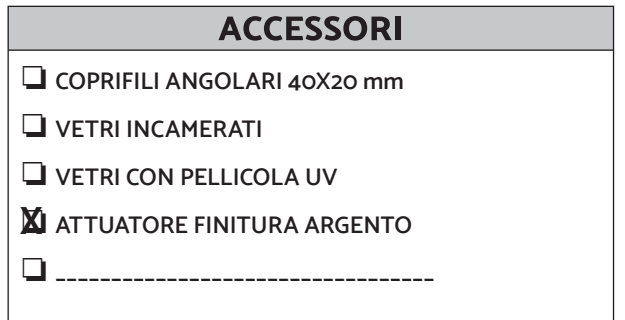
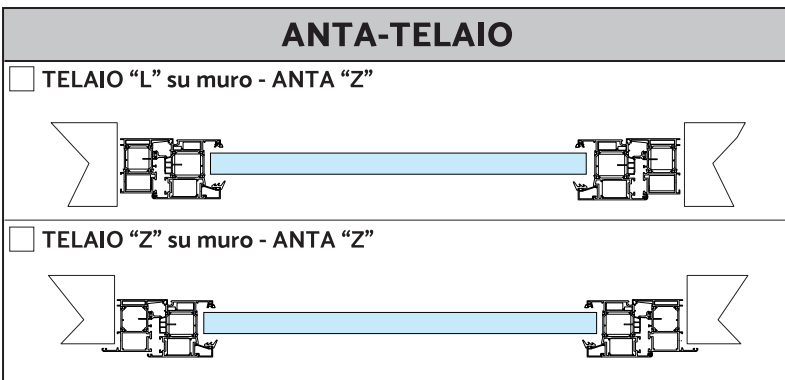
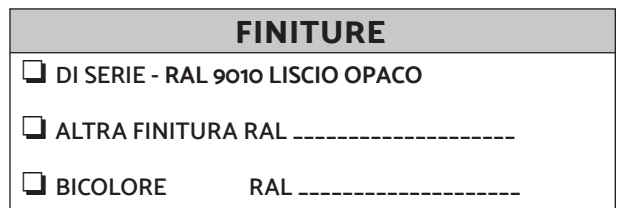
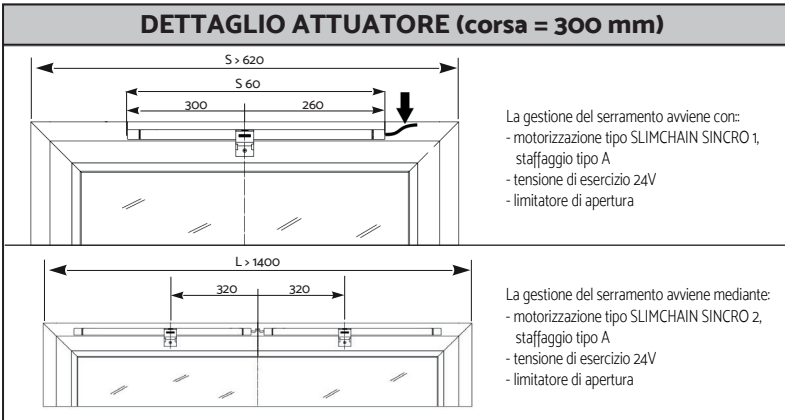
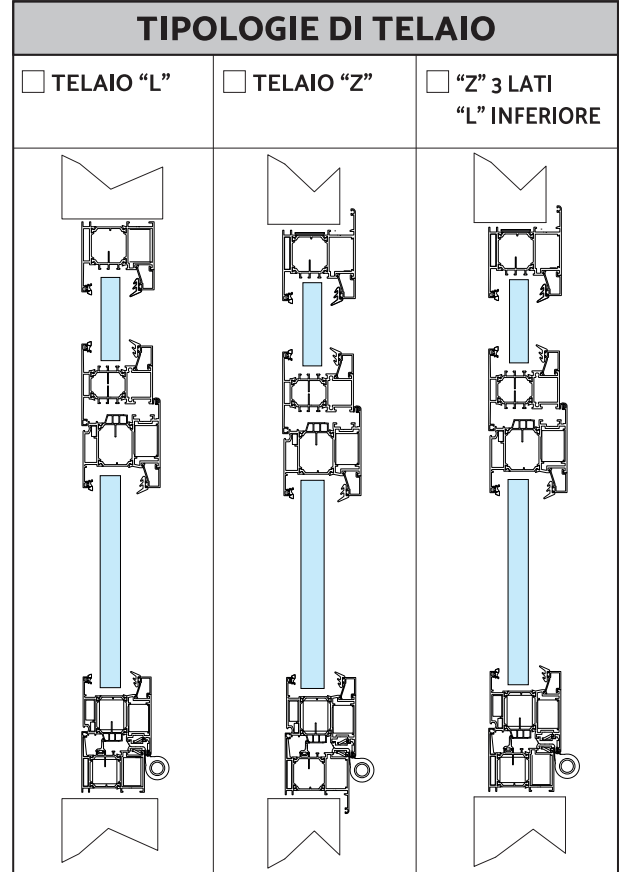

NOTE:

Timbro e firma per accettazione

Cliente _____ Rif. ordine / Offerta _____ Data ____ / ____ / ____ Rif. _____ Ubicazione _____

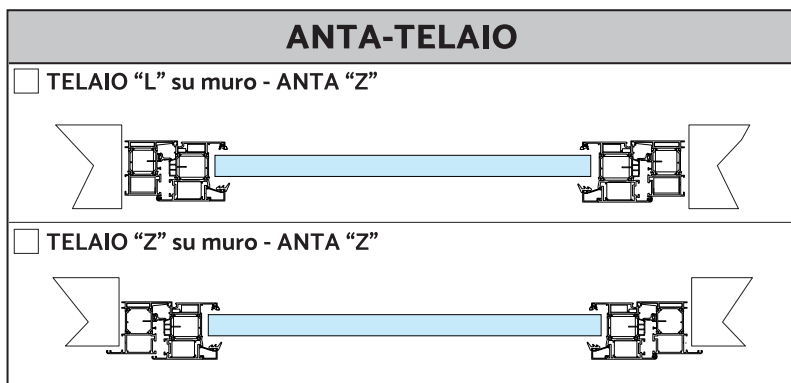
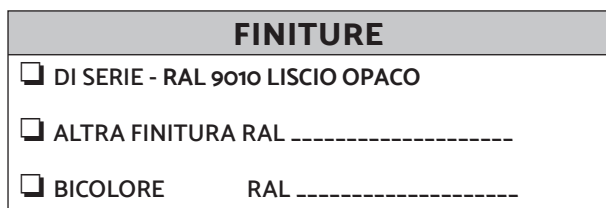
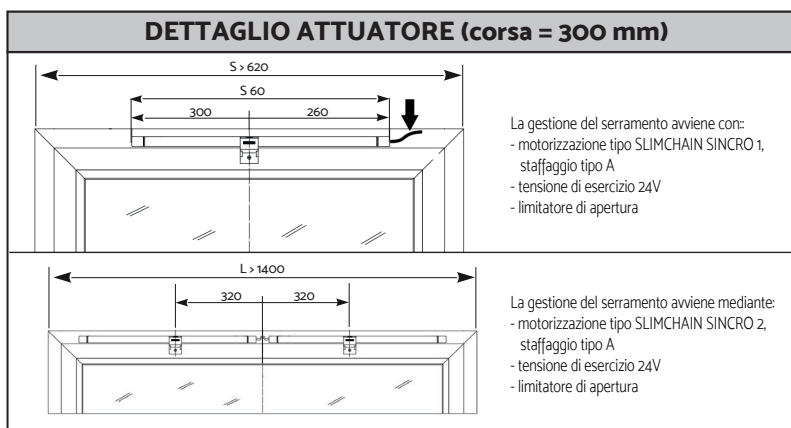
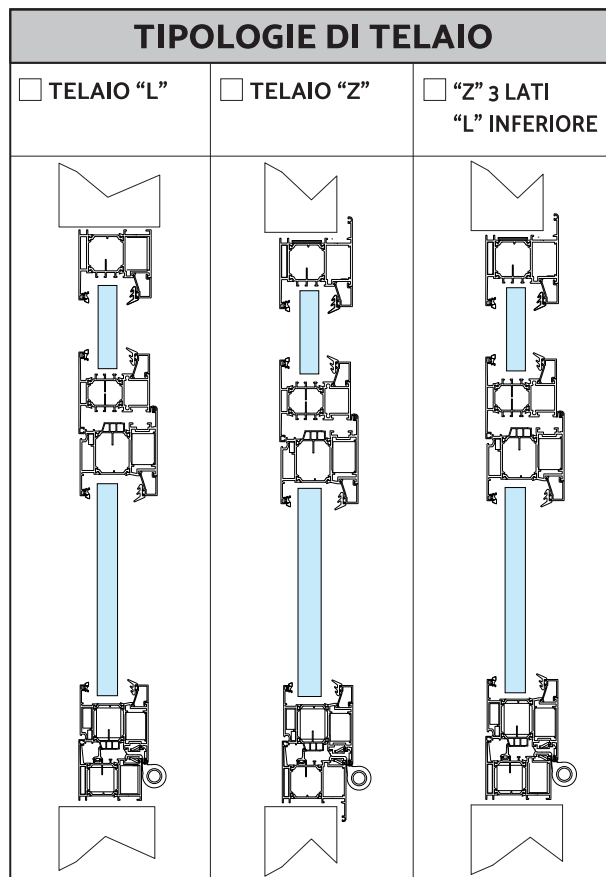
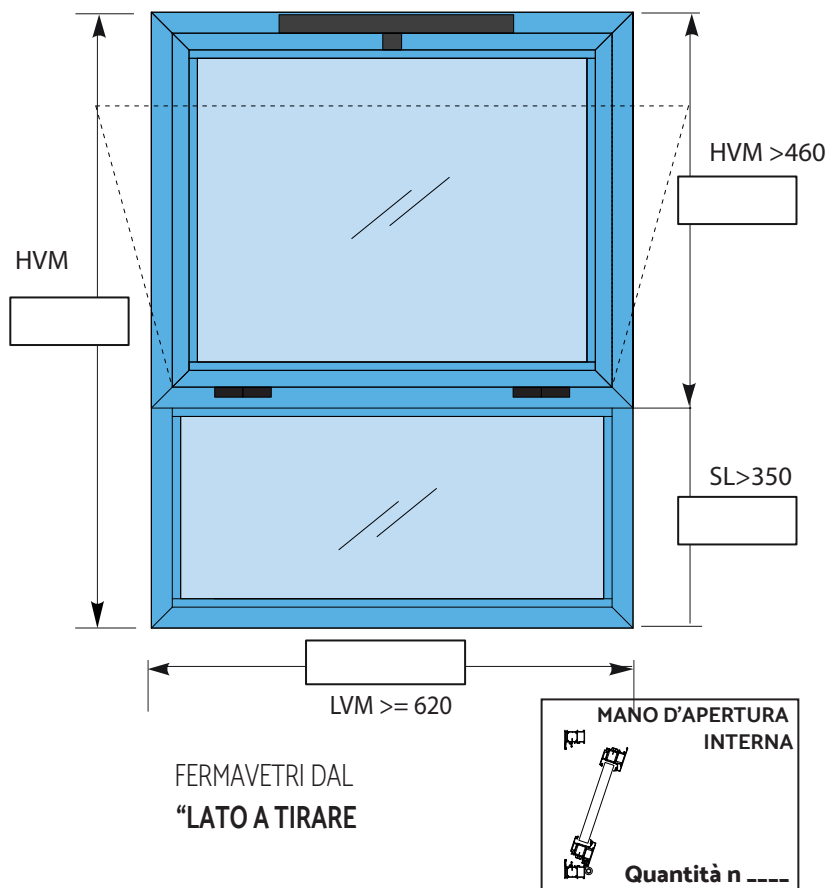

Timbro e firma per accettazione

NOTE:

SERRAMENTI TAGLIAFUOCO
Tel.: +39 0832 757979
E-mail: info@glassfire.it

EI 30
Sp. = 75 mm

EI 60
Sp. = 75 mm

EI 90
Sp. = 75 mm

Cliente _____ Rif. ordine / Offerta _____ Data / / Rif. _____ Ubicazione _____

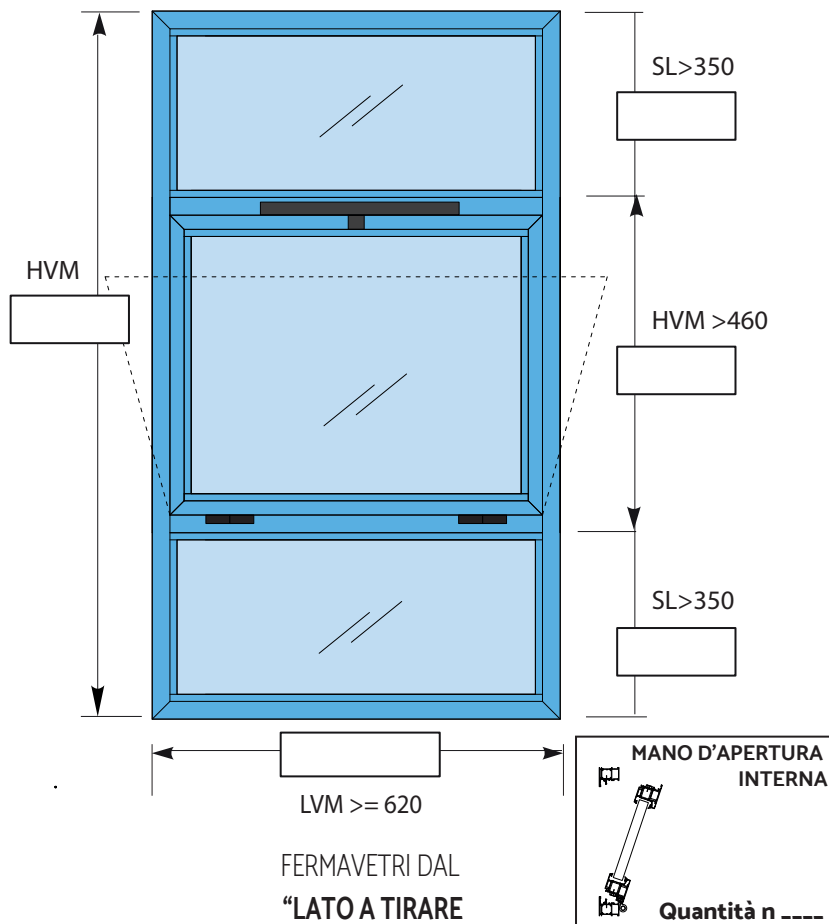

DETTAGLIO ATTUATORE (corsa = 300 mm)

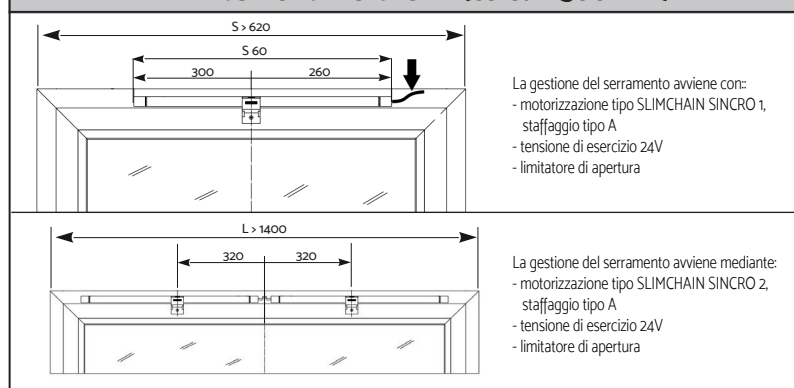

ANTA-TELAIO

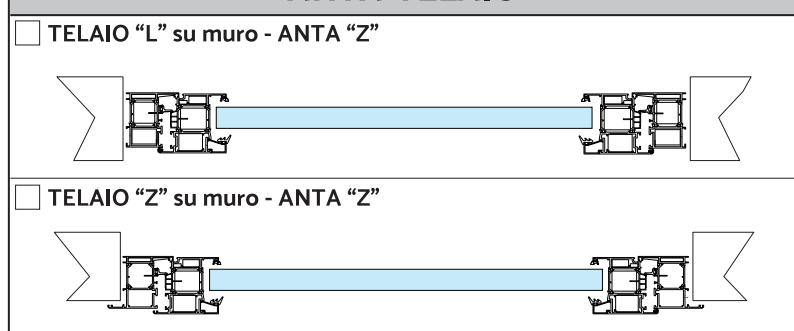

TIPOLOGIE DI TELAIO

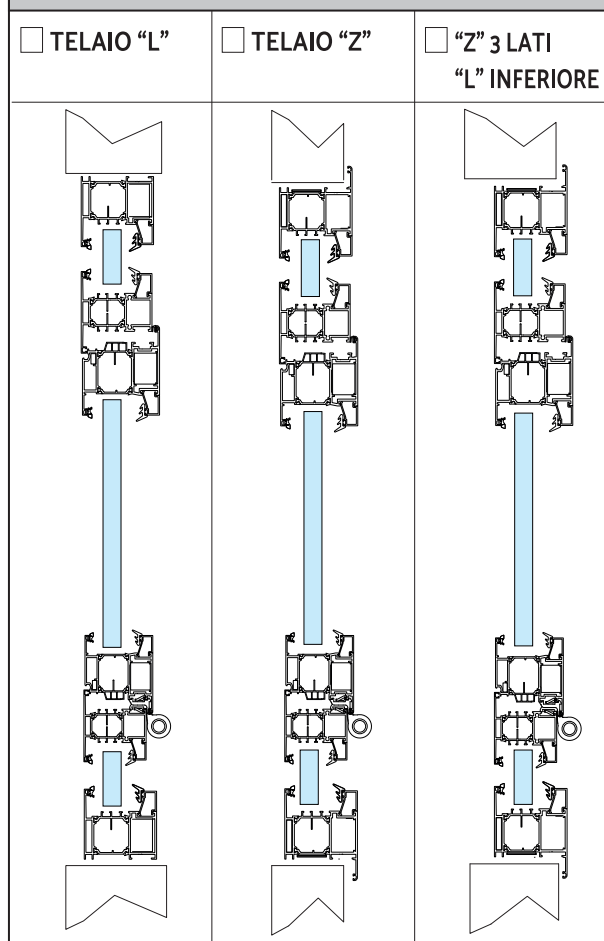

TIPOLOGIE DI FISSAGGIO

- FORI DI ANCORAGGIO PER SOTTOSTRUTTURA
- FORI DI ANCORAGGIO PER TASSELLI

FINITURE

- DI SERIE - RAL 9010 LISCI0 OPACO
- ALTRA FINITURA RAL _____
- BICOLORE RAL _____

ACCESSORI

- COPRIFILI ANGOLARI 40X20 mm
- VETRI INCAMERATI
- VETRI CON PELLICOLA UV
- ATTUATORE FINITURA ARGENTO
- _____

NOTE:

Timbro e firma per accettazione

Cliente _____ Rif. ordine / Offerta _____ Data ____ / ____ / ____ Rif. _____ Ubicazione _____

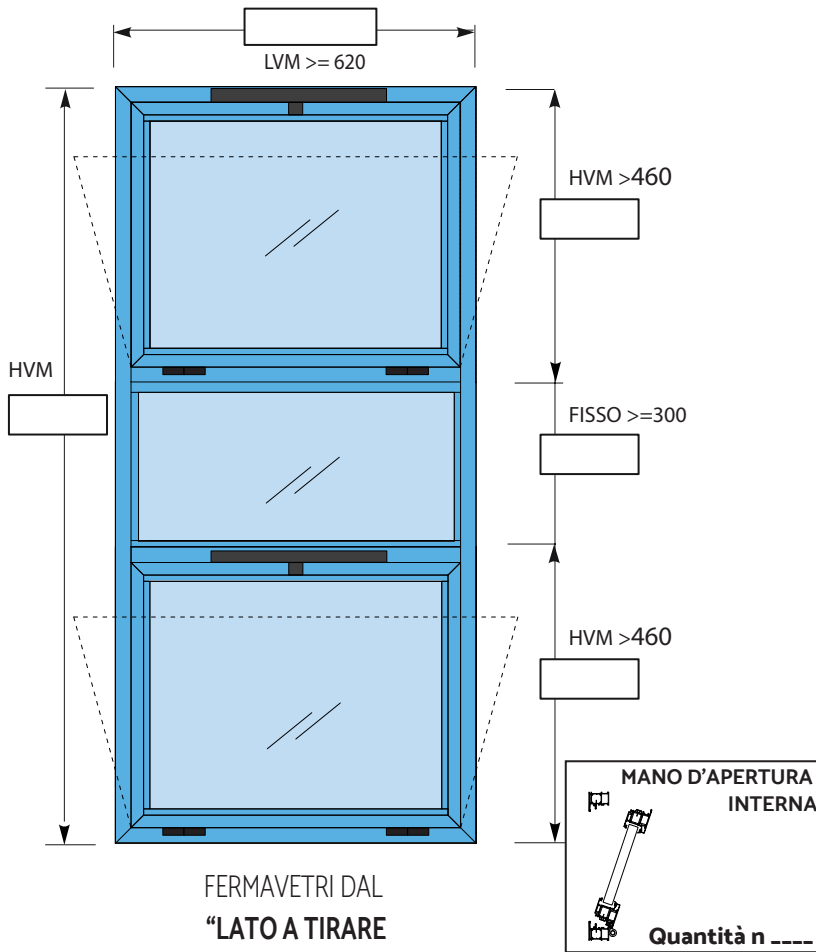

DETTAGLIO ATTUATORE (corsa = 300 mm)

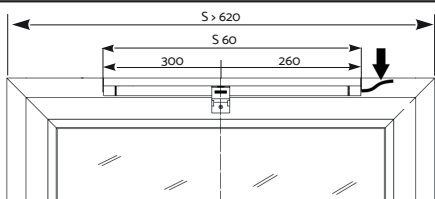

La gestione del serramento avviene con:
- motorizzazione tipo SLIMCHAIN SINCRO 1,
staffaggio tipo A
- tensione di esercizio 24V
- limitatore di apertura

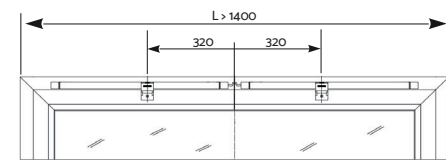

La gestione del serramento avviene mediante:
- motorizzazione tipo SLIMCHAIN SINCRO 2,
staffaggio tipo A
- tensione di esercizio 24V
- limitatore di apertura

ANTA-TELAIO

TELAIO "L" su muro - ANTA "Z"

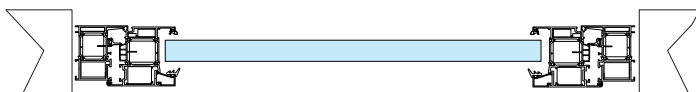

TELAIO "Z" su muro - ANTA "Z"

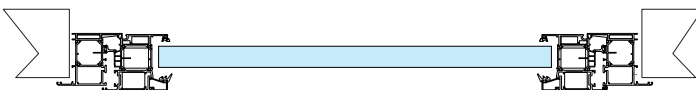

TIPOLOGIE DI TELAIO

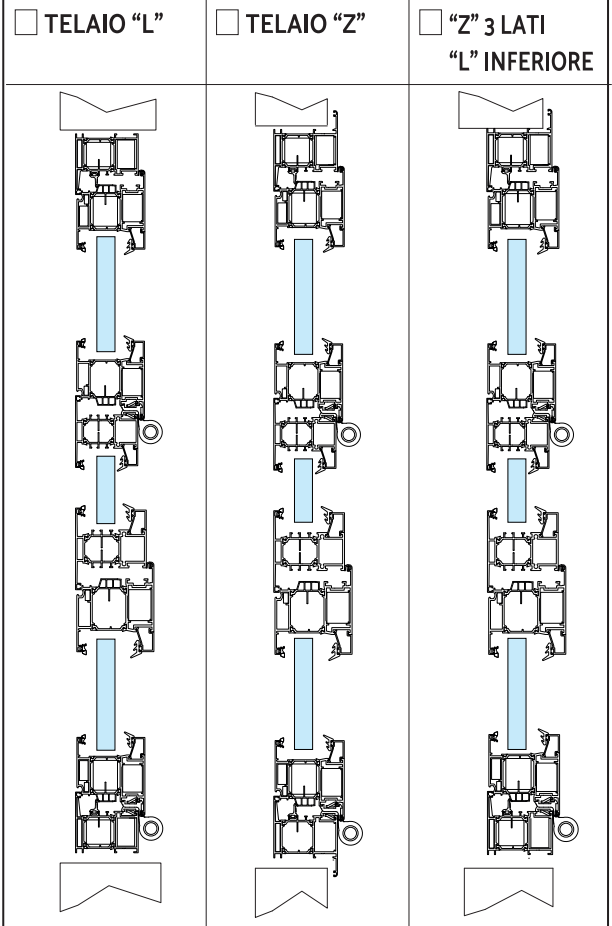

TIPOLOGIE DI FISSAGGIO

- FORI DI ANCORAGGIO PER SOTTOSTRUTTURA
- FORI DI ANCORAGGIO PER TASSELLI

FINITURE

- DI SERIE - RAL 9010 LISCIO OPACO
- ALTRA FINITURA RAL _____
- BICOLORE RAL _____

ACCESSORI

- COPRIFILI ANGOLARI 40X20 mm
- VETRI INCAMERATI
- VETRI CON PELLICOLA UV
- ATTUATORE FINITURA ARGENTO
- _____

NOTE:

Timbro e firma per accettazione